

# ROTEL<sup>®</sup>

## RP-1000

STEREO RECORD PLAYER



# TECHNICAL MANUAL

## PREPARATION FOR ASSEMBLY

Your unit is well protected against vibration or impact during transportation. The player assembly body and the phono motor are firmly fixed by screws, and the turntable, the cartridge and the counter-balance weight are separately packed. Accordingly, make the following preparations before assembling.

1. Loosen the screws clamping the player body, so that the body "floats" on the springs underneath. Remove the screws clamping the phono motor with a screwdriver or a coin. See Figure 2 for the locations of the screws.
2. Set the blank section of the center gear opposite the turntable shaft by manually rotating the gear. Push the trips of the gear inward as shown in Figure 2.  
Never turn the gear and the turntable in the opposite direction of normal rotation.

NOTE: Always clamp the player body and fasten the phono motor with the screws when moving the unit for considerable distance.

### IMPORTANT: CHECKING VOLTAGE SELECTOR

With the use of the 4-pole hysteresis synchronous motor, RP-1000 maintains constancy of speed, unaffected by fluctuations in load or in line voltage. RP-1000 is wired for both 100 volts (usable 100 to 120 volts) and 220 volts

(usable 200 to 240 volts). Although the voltage has been set to your area in our factory prior to shipment, make sure of it by checking the position on the Power Voltage Selector Switch (on the Player Assembly Body). If the voltage setting somehow differs from your local power source, simply switch to the proper position by using the philipstype screwdriver (refer to Figure 1) to loosen the placement latch.

NOTE: If the player is set for 110 volts 220 volts load will burn the motor; if the player is set for 220 volts, 110 volts load will be insufficient for proper motor operation.

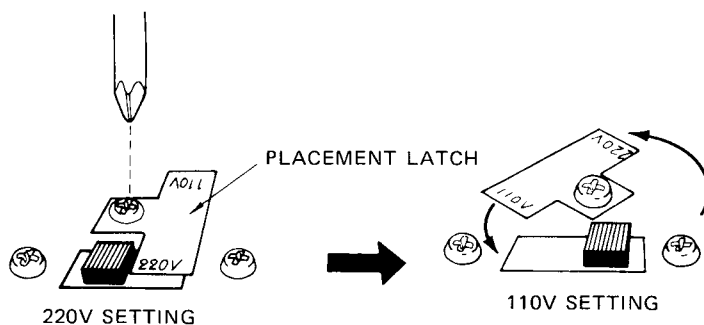

Figure 1

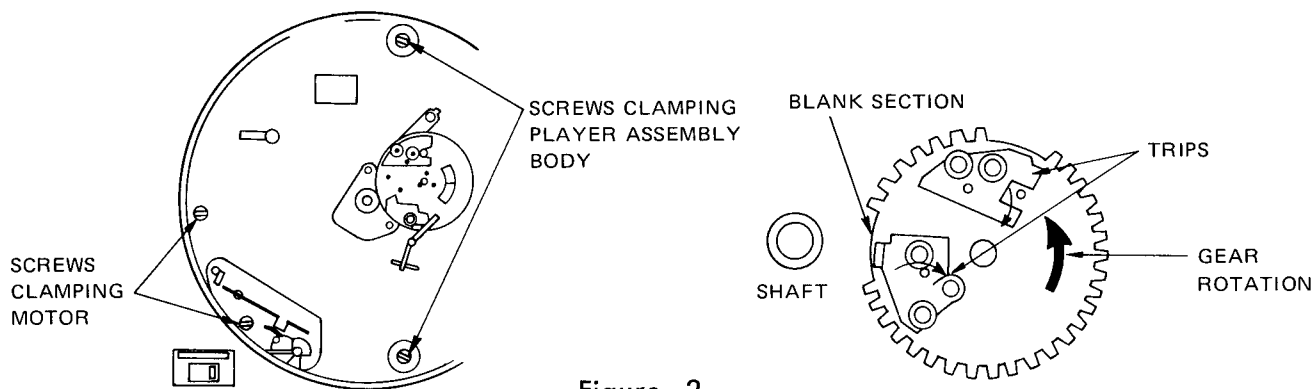

Figure 2

## ASSEMBLING

### TURNTABLE AND BELT

1. Find the Belt around the Drive Rim of the Turntable (Drive Rim is on the backside of the Turntable). Wipe clean any dust and oil from the Belt. Also, make sure there is no dust in the center hole of the Turntable platter and on the surface of the Turntable to avoid inclined setting of the platter.
2. Put the Turntable on the Player Assembly Body. Loop the Belt around the Capstan and the Drive Rim, making sure that the Belt passes through the center of the belt guide. Make sure the Belt will be on the narrowest part of the Capstan when the Speed Selector Switch is on 33 1/3 r.p.m., and on the wide part when 45 r.p.m. See Figure 3 for looping the Belt.

3. Place the Rubber Mat with the smooth surface down on the Turntable platter.
4. Place the Center Spin Plate on the Rubber Mat.

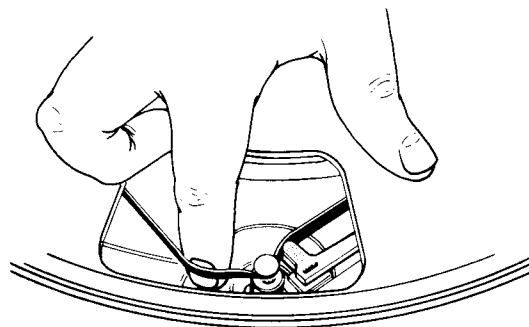

Figure 3

## TONE ARM

1. Plug the Head Shell (with its pre-equipped cartridge) into the front end of the Tone Arm, and secure it by turning the Lock clockwise (wipe clean all dust from the connecting points of the Head Shell and leave the Stylus Cover on when handling). See Figure 4.
2. Insert the Circular Counter-Balance Weight about 3/4" into the end portion of the Tone Arm. The weight moves forward to clockwise revolutions and backward to counter-clockwise revolutions. See Figure 4.

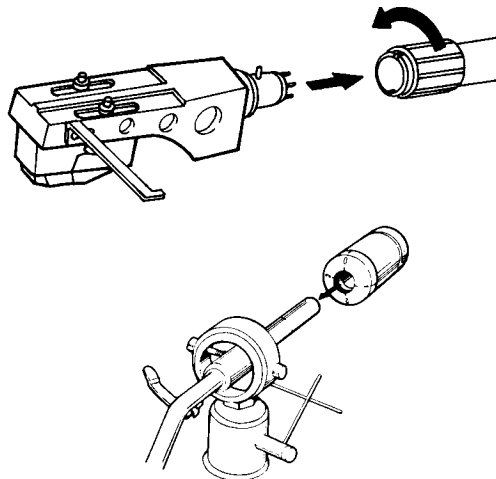

Figure 4

## OPERATION ON DIFFERENT CYCLES

When operating the unit in an area with different cycle, proceed as follows:

ITEM \ CYCLE	50Hz AREA	60Hz AREA
Capstan		
Motor Power Source	Power supply leads of motor terminal are not to be changed.	

Figure 5

## ADJUSTMENT

### [1] Adjustment for proper Auto-Return Point

- In case of a slight off-position:
  1. Turn the adjust screw clockwise if relocating the returning point inward.
  2. Turn the adjust screw counter-clockwise if relocating the returning point outward.
- In case of a large off-position/or readjustment after disassembling:
  1. Set the stylus tip 60 mm (2½ in.) away from the center of turntable.
  2. Push the operating arm fully toward the center of turntable. (The blank section of center gear will be directly facing the turntable shaft.)
  3. Loosen the screw securing the shifting arm and temporarily fix the arm approximately 40mm away from the operating arm.
  4. Adjust the shifting arm for proper location by rotating the adjust screw.

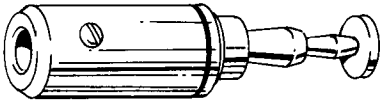
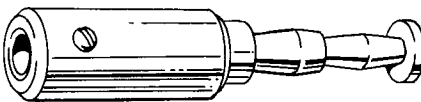
### [2] Adjustment for proper Auto-Return of Tone Arm

If the tone arm does not return to the arm rest during operation, or returns too hard to the arm rest, make the adjustment as follows:

1. Remove the turntable platter.
2. Bring the tone arm fully toward the center of turntable by hand.

3. Slowly rotate the center gear counter-clockwise by hand.
4. When the movement of tone arm comes to maximum (about half turn after the arm elevates and starts to move toward the arm rest), adjust the contacting stroke to the bending part of the operating arm by rotating the center bias pin.

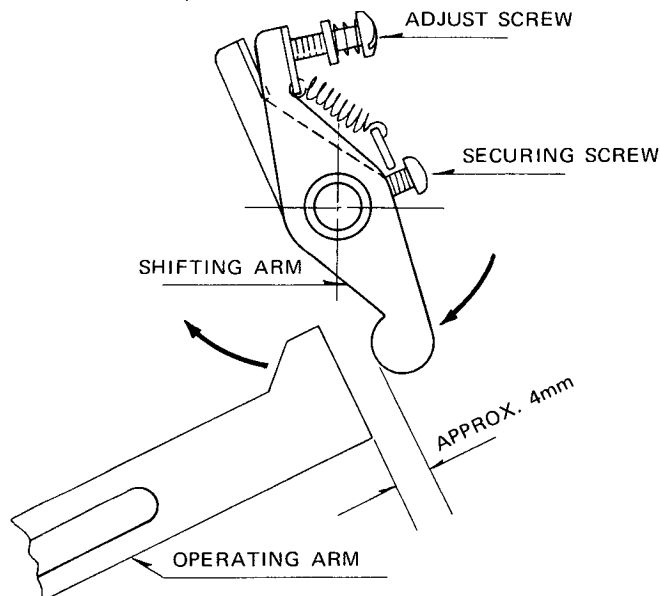

Figure 6

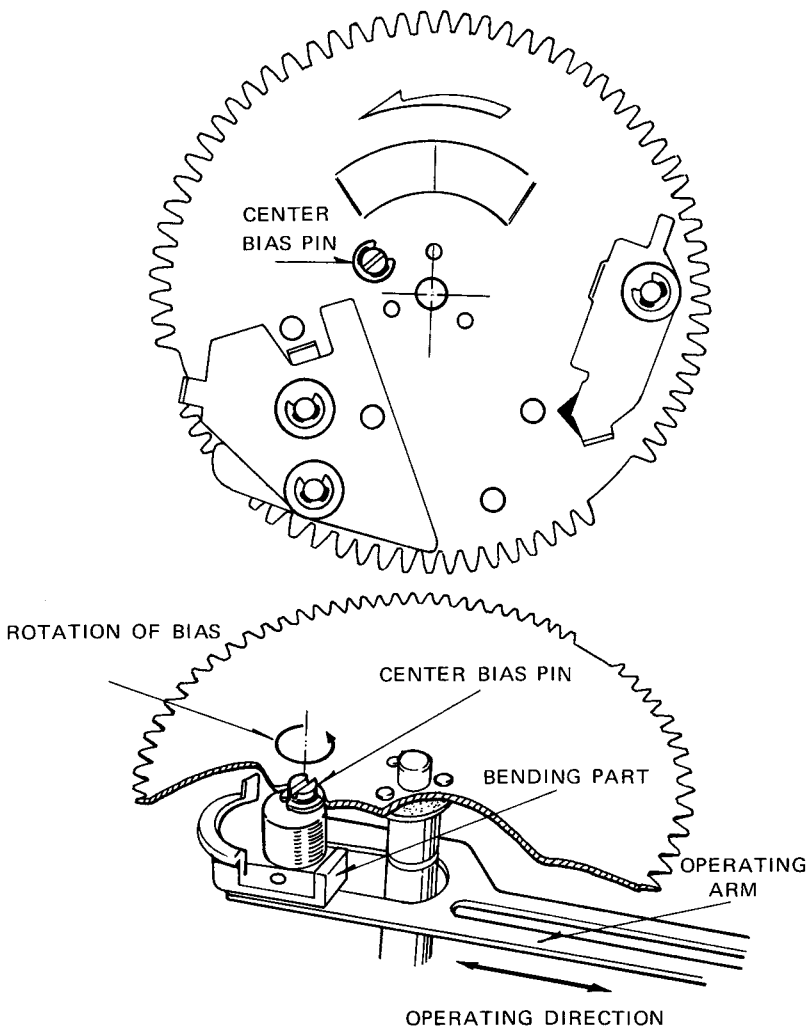

Figure 7

[3] Adjustment for Proper Stylus Height

If the stylus height is too high or too low in reference to the turntable platter due to the change of cartridge or other reason, correct it by placing the stylus tip on a record disc in REJECT mode, and bending the seasaw arm head slightly.

Bend upward for increase in height.

Bend downward for decrease in height.

The proper height can be estimated as seven times taller than the stylus tip.

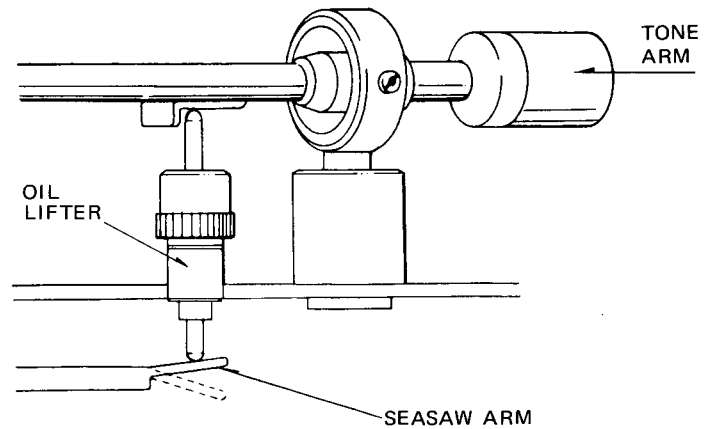

Figure 8

## MAINTENANCE

[1] Lubrication

The rotating parts require no lubrication because of the use of oilless metal, but one or two drops of oil every six months may assure a longer life.

[2] Material of Oil

Use high quality oil such as sewing machine oil or watch oil, etc.

[3] Oiling Point

Turntable shaft and motor shaft.

[4] Caution

Be careful not stain the belt with oil when lubricating. If belt is stained, wipe off with carbon chloride or alcohole.

# TROUBLE SHOOTING

Item No.	Symptom	Cause	Remedy
1	Turntable does not turn when setting lever to PLAY	1. No current to motor due to faulty contact of micro-switch with switch spring	1. Check switch spring pressure 2. Check micro-switch
		2. Idler does not mesh properly with pulley	1. Check interlocking device between idler lever and idler arm
		3. Broken lead wire	1. Check the connection of lead wire
		4. Faulty motor	1. Replace motor
2	Tone arm does not return when setting lever to REJECT	1. No activation of operating arm	1. Check interlocking device between lever, starting spring and operating arm 2. Check motion by friction or contact between operating arm and panel 3. Check fastening of operating arm
		2. Faulty gear	1. Check operating condition of cratch gear 2. Check the convex shape of turntable gear
		3. Front of the operating arm gets in beneath the bottom bending part of cratch gear	1. Move operating arm back toward tone arm and bend the head of operating arm upward
3	Though tone arm returns to arm rest, the unit is not turned off and idler does not go off	1. Pressure of switch spring is too strong.	1. Check the angle and pressure of switch spring
		2. Faulty positioning of cutter arm	1. Check contact of cutter arm with releasing shaft of idler lever
4	Tone arm returns by itself	1. Faulty positioning of shifting arm (deflection toward turntable)	1. Adjust the position of shifting arm
5	Annoying shock sound during auto-return	1. Faulty contact of turntable gear with center gear	1. Check (replace) center gear 2. Check (replace) turntable platter
		2. Over-protrusion cratch gear or deformation of cratch gear head	1. Check the pitch between center gear and turntable shaft
6	Tone arm does not return completely to the arm rest after auto-return	1. Crooked operation angle of operating arm	1. Bend operation angle to right angle (or replace operating arm)
		2. Center bias pin of center gear does not push the operating arm	1. Change the degree of deflection by rotating center bias pin.
		3. Returning position lies much toward turntable center	1. Adjust the returning position toward outside direction of turntable
7	Stylus slips on the disc during auto-return	1. Faulty adjustment of height of oil lifter	1. Check the screw of oil lifter 2. Check curvature of record disc 3. Bend slightly the seasaw arm head up or down

# REPAIR PARTS LIST

Part No. PART NUMBER	Description DESCRIPTION
090121111	Headshell
090129117	Lift Assembly, Tone arm
090126118	Arm Rest, Tone arm
090121119(-20)	Capstan, 50 (or 60 Hz) [specify when ordering]
090129121	Belt
090127134	Hinges
090121129	Knob, Play/Reject Switch
090126130	EP (45 rpm) Adaptor
090121127	Rubber Mat, Turntable
090121128	Spin Plate, Turntable
090126137	Rubber Feet
090129133	Dust Cover
090126124	Switch, Voltage Selector
090127132	Connection Cords, Low Capacitance
090128139	Styrofoam Side Moulding, Carton Box
—	Cosmetic Carton Box

Refer to model number, part number and description when ordering for repair parts.

Specifications  
 Technische Daten  
 Caractéristiques

Repair Parts List **RP1000 (NEW)**  
 Reparaturteilliste  
 Liste des pièces de rechange

**MOTOR AND TURNTABLE**

Motor . . . . . DC FG Servo Motor  
 Drive . . . . . Direct-drive System  
 Speed . . . . . 33 1/3rpm and 45rpm  
 Wow and Flutter . . . . . 0.03% (JIS, WRMS)  
 Speed Control Range . . . . . ±4% (individual control for  
 33 1/3 and 45rpm)  
 Signal-to-Noise Ratio . . . . . Better than 60dB (IEC-B)  
 Better than 70dB (DIN-B)  
 Platter . . . . . Aluminum Diecast (310mm  
 diameter with strobe rim)

**TONE ARM**

Type . . . . . Static-balanced Straight Pipe  
 Arm with Plug-in Headshell,  
 Oil-damped Cueing Device,  
 Direct-readout Stylus Gauge  
 Counter Weight, Anti-skating  
 Device  
 Overhang . . . . . 17mm  
 Tracking Error . . . . . +2.4° to -1.2°  
 Suitable Cartridge Weight . . . . . 4g to 12g  
 Suitable Stylus Pressure . . . . . 0.75g to 3g

**MISCELLANEOUS**

Power Requirement . . . . . 120/220/240V (switchable)  
 50Hz/60Hz  
 Power Consumption . . . . . 5 watts max.

**CARTRIDGE (2RC-5) (optional)**

Type . . . . . Variable Magnetic (VM) Type  
 Frequency Response . . . . . 20 to 25,000Hz  
 Channel Separation . . . . . 28dB at 1,000Hz  
 Load Impedance . . . . . 47 kilohm  
 Compliance . . . . . 6.3 x 10<sup>-6</sup> cm/dyne  
 Stylus Pressure Range . . . . . 1.5g to 2.5g  
 Stylus Tip . . . . . 0.6 mil diamond  
 Cartridge Weight . . . . . 5.5g  
 Replacement Stylus Type . . . . . RN-5

**Note:** Specifications subject to change without prior notice.

Schematic Location	Description	Part No.
<b>TRANSISTORS, DIODES AND IC'S</b>		
X1, 2, 3, 4	2SC945 (K) or 2SC2308 (B or C)	301201111 301201215 301201218
X5	2SA733 (Q or P) or	301001174
X5 EQ	2SA564A	301001177
X6, 7	2SB647 (B or C)	301101130
X8, 9	2SD667 (B or C)	301301143
IC1, 2	NJM4558D	303452215
ZD1, 2	WZ-061, Zener Regulator, 6.1V 0.5W	300313052
D1, 2, 3, 4	W03B, Rectifier	300919042
<b>POTENTIOMETERS</b>		
VR1, 2	5KB, Speed Adj	092045111
VR3, 4	10KB, Wow Adj	092045112
VR5	300B, Wow Adj	092045113
<b>FUSES</b>		
F1, 2	1A, 250V, -3AG (for 120V) 500mAT, 250V, Midget (for 220V/240V)	341222200 345952050

**Note:** The above list does not include those components and parts listed in the Disassembly Diagram.

Disassembly Diagram  
Aufbaudiagramm  
Diagramme de démontage

RP 1000 (NEW)

No.	Description	Part No.	No.	Description	Part No.
1.	Sub-chassis Ass'y	NSP	41.	Arm, Elevation	092041017
2.	Return Gear Ass'y (2)	092046501	42.	Spring, Elevation Arm	092046509
2-1.	Return Gear Ass'y (1)	092046511	43.	Screw, M3 x 14mm (BLZ)	703223014
2-2.	Clutch Plate	092041137	44.	Cueing Arm	092041018
2-3.	Clutch Guide	092041138	45.	Cueing Lever	092041019
2-4.	E-ring, $\phi 3$	770500039	46.	Base Plate, Tone Arm	092041020
3.	Actuating Arm	092041002	47.	Cap, Cueing	092041021
4.	Steel Ball, $\phi 4$	651010114	48.	Restore Lever Ass'y (2)	092041022
5.	Base, Actuating Arm	092041003	49.	Knob Ass'y, IFC	092041023
6.	Screw, + 3 x 12mm, B-tight	092047021	50.	Friction Washer	092047002
7.	Kick Lever	092041004	51.	Spring, IFC	092046510
8.	Not Used	—	52.	Cam, IFC	092041024
9.	E-ring, $\phi 3$	770500039	53.	Flange Screw, 3 x 8mm, Tapping-II	092047025
10.	Operative Arm, for 120V Type	092041005	54.	Lug Terminal Ass'y	791001145
	" , for 220V/240V Type	092041119	54-1.	Lug Terminal, 5P (2E2)	645302002
11.	Washer, $\phi 3.2 \times \phi 10 \times t0.5$	770500072	54-2.	Shield Cord Ass'y	791001142
12.	E-ring, $\phi 2$	770500035	54-3.	Varnish Tube	792011207
13.	Spring 1	092046502	55.	Motor Ass'y (including control circuit), for 120V Type	260101124
14.	Arch E-ring, $\phi 6$	770500073		Motor Ass'y (including control circuit), for 220V/240V Type	260101125
15.	Eccentric Pin (2)	092047001	56.	Washer, $\phi 4.2 \times \phi 12 \times t1$	770500074
16.	Washer, $\phi 5.2 \times \phi 10 \times t0.2$ (BsP)	770500068	57.	Screw, 4 x 20mm, C-tight	765204020
17.	Screw, + 3 x 8mm, B-tight	092047017	58.	Metal Fittings, Power Cord Mtg, for 120V Type	092041025
18.	Screw, + 3 x 6mm, Tapping-I	092047020		Metal Fittings, Power Cord Mtg, for 220V/240V Type	092041026
19.	Power Supply PCB Ass'y, for 120V Areas	092041006	59.	Cord Stopper, for 120V Type	675201111
	" , for 220V Areas	092041007		" , for 220V/240V Type	675201119
	" , for 240V Areas	092041008	60.	Bottom Cover Ass'y	092041027
19-1.	Power Supply PCB	092041136	60-1.	Bottom Cover	092041139
19-2.	Neon Lamp, for 120V	092043111	60-2.	Foot	673402016
	Neon Lamp, for 220V/240V	092043114	60-3.	Flange Nut, M3	770402215
19-3.	Power Switch, for 120V Type	615212278	60-4.	Screw, M3 x 10mm	705203010
	" , for 220V/240V Type	615212257	61.	Screw, 4 x 12mm (Ni), Tapping-I	092047026
19-4.	Power Supply Cord, for 120V	796301151	62.	Dust Cover Ass'y	092041028
	" , for 220V	796301152	62-1.	Dust Cover	092041029
	" , for 240V	796301138	62-2.	Plate	092041031
20.	Wire Fastener	672200859	62-3.	Hinge Ass'y <i>1201</i>	092041030
21.	Insulator (Not used for 120V type)	991001169	62-4.	Screw, M4 x 8mm (BLZ), Truss Head	707224008
22.	Screw, M2.6 x 14mm (Fe), for 120V Type Only	703202614	63.	Turntable Platter	092041032
	Screw, M2.6 x 15mm, Polycarbonate, 220V/240V Type Only	092047022	64.	Turntable Sheet	672301115
23.	Power Transformer, for 120V Type	201001493	65.	EP Adaptor	648211249
	" , for 220V Type	202001493	66.	Name Plate	092041033
	" , for 240V Type	203001493	67.	Lug, Clamper	770031333
24.	Screw, 4 x 10mm, Tapping-I	092047023	68.	Tube, $\phi 3.3 \times 60\text{mm(L)}$	792011206
25.	Controls Ass'y	092041009	69.	Washer, $\phi 3.2 \times \phi 8 \times t5$	770500060
25-1.	Metal Fittings, Variable Resistors Mtg	092041010	70.	Circular External Ring, CSTW-3	770911252
25-2.	Variable Resistor	515321119	71.	Shield Cover	092041034
25-3.	Push Switch	092046503	72.	Cover, Restore Lever (Not used for 120V type)	092041079
26.	Knob, Speed Control	092041011	73.	Cabinet	092041035
27.	Button, Speed Selector	092041012	74.	Wire Ass'y, Chassis Ground	791001141
28.	Prism	092041013	75.	Flange Nut, M4	770402218
29.	Holder, Neon Lamp	092046504	76.	Cartridge, 2R-C5	901001121
30.	Button, Reject	092041014	77.	Nut, M10	770402216
31.	Spring, Reject Button	092046505	78.	Teethed Washer, M10	770500075
32.	E-ring, $\phi 3.2$	770500045	79.	Screw, M2.6 x 10mm, (Al)	092017025
33.	Reject Lever	092041015	80.	Nylon Washer, M2.6	092017005
34.	Spring, Reject	092046506	81.	Circular Nut, M2.6 (Al)	092017006
35.	Arm Rest	092041016			
36.	Screw, 3 x 6mm, B-tight	092047024			
37.	Flange Nut, M3	770402215			
38.	Tone Arm Ass'y	902111124			
38-1.	Pipe Arm Ass'y	902111127			
38-2.	Head Shell	150011255			
38-3.	Main Weight Ass'y	092011041			
39.	Shaft, Elevation	092046508			
40.	Spring, Elevation	092046507			



RP1000  
(NEW)

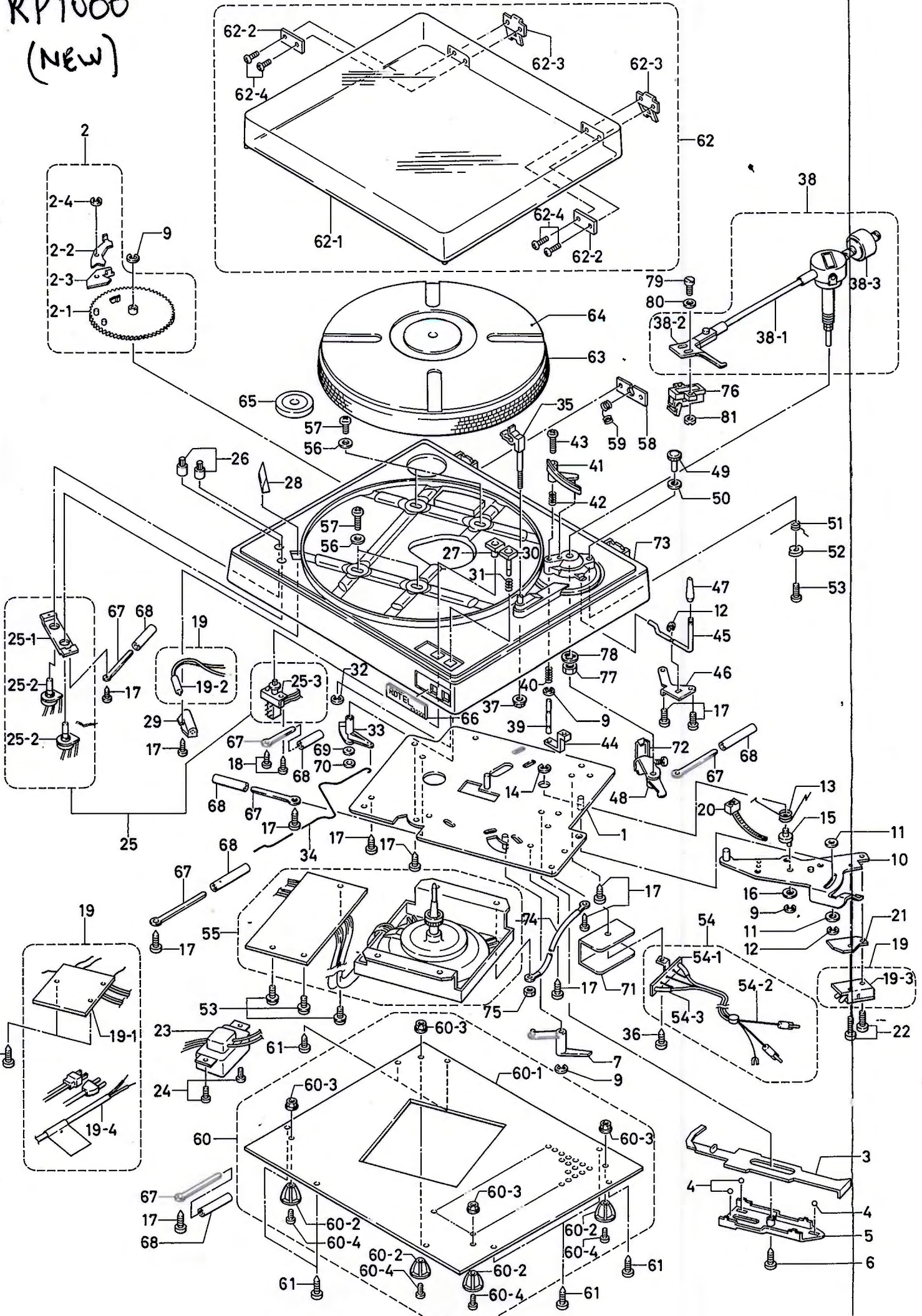

1-  
2 0  
3 0  
4 -  
5 0  
6 0  
7 -  
8 +

# Schematic Diagram Schaltungsschema Diagrama

## RP1000 (Nkw)

C001

120V	LH0022
220V	LH0047
240V	

R001

120V	2W12K
220V	2W33K
240V	

PL1

120V	092043111
220V	092043114
240V	

FUSE 1.2

120V	250V1A
220V	250V
240V	500mA

T001

120V	871920
220V	871921
240V	871927

*Pins 12 & 13.*  
  
*is fig*  
*xy should be circular*

*Ic1 running @ 33.*  
*Rin*  
 1 - 0.128 → +0.122 approx N  
 2 - 0.02  
 3 - 0  
 4 - 12V  
 5 - 0.107 → +140V approx  
 6 - 0.107 → +140V approx  
 7 - 5 → -7. N approx  
 8 - +12V

### NOTES

- Ic2 running at 33 rpm*
- 1) IC1, IC2: NJM4558D / RC4558P  
 JPC1458C / JPC4558
- 2) X1 ~ X4: 25C945 / 25C2308  
 3) X5: 25A733 / 25A641  
 4) X6 ~ X7: 25B562 / 25B647  
 5) X8 ~ X9: 25D468 / 25D667
- 6) ZD1, ZD2: WZ061  
 7) D1 ~ D4: W03B / W03C / F14C
- 1 - 2.2 → +2.2 N approx  
 2 - 0.12 → 0.49 N approx  
 3 - 0.11 → 0.49 N approx  
 4 - 12V  
 5 - 0.09 → 0.49 N approx  
 6 - 0.11 → 0.59 N approx  
 7 - 2.2 → +2.2 N approx  
 8 - +12V

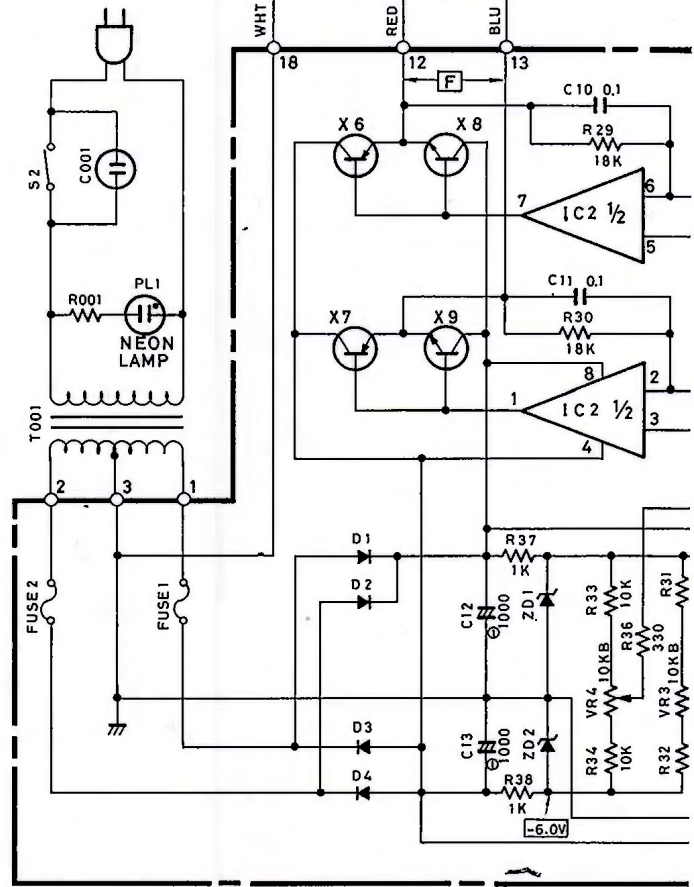
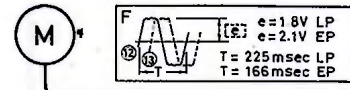

2RC-5

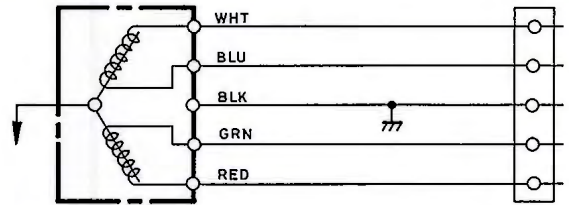

### MOTOR CONTROL CIRCUIT MOTOR-REGLER-LEITERPLATTE CIRCUIT DE COMMANDE DU MOTEUR

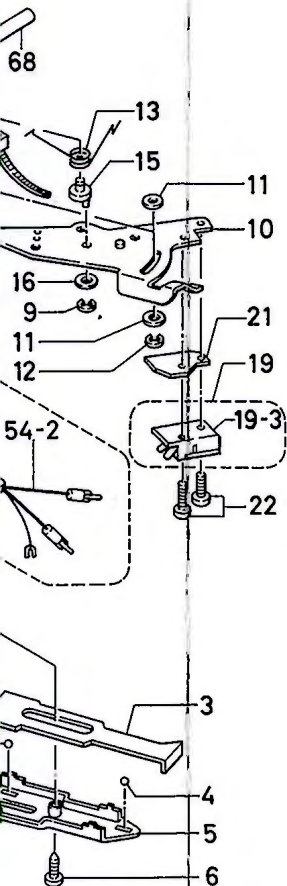
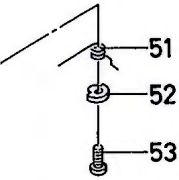
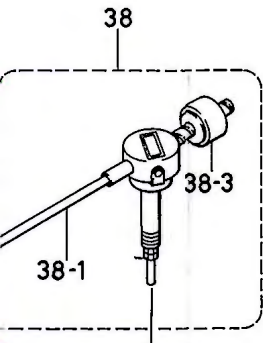
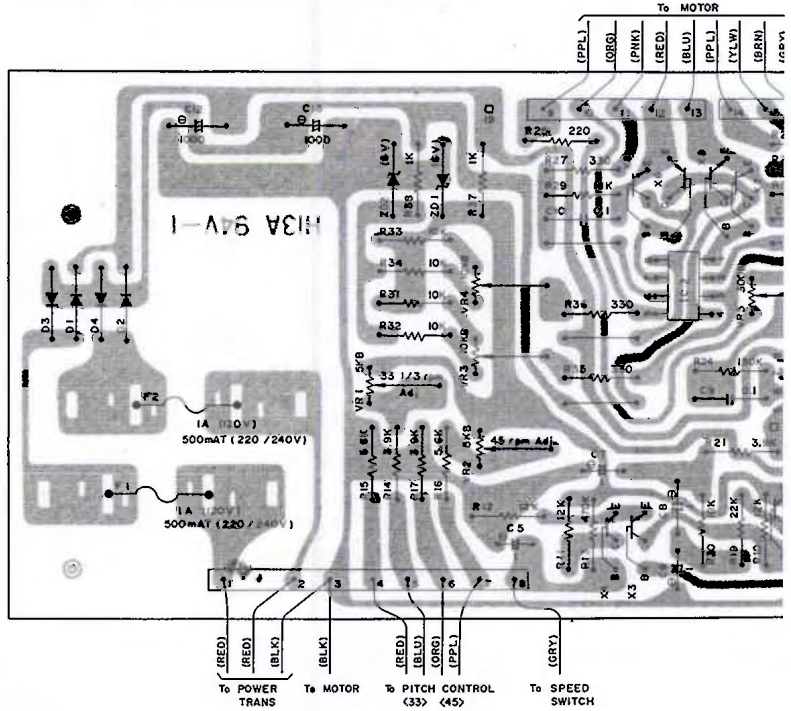

# Diagramme schématique

RP1000 (NEW)

NOTES  
 VOLTAGES AND WAVEFORMS  
 MEASURED WITH RESPECT TO  
 PIN No.3 USING DIGITAL MULTI-  
 METER AND OSCILLOSCOPE

• VOLTAGE INSIDE □ MEASURED  
 BY DIGITAL MULTIMETER  
 • VOLTAGE INSIDE ◻ MEASURED  
 BY OSCILLOSCOPE

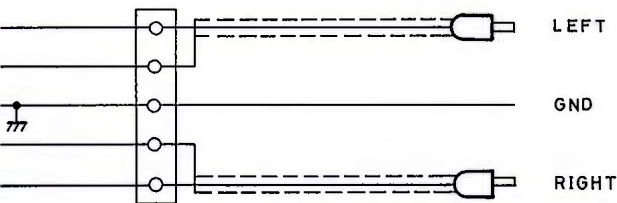
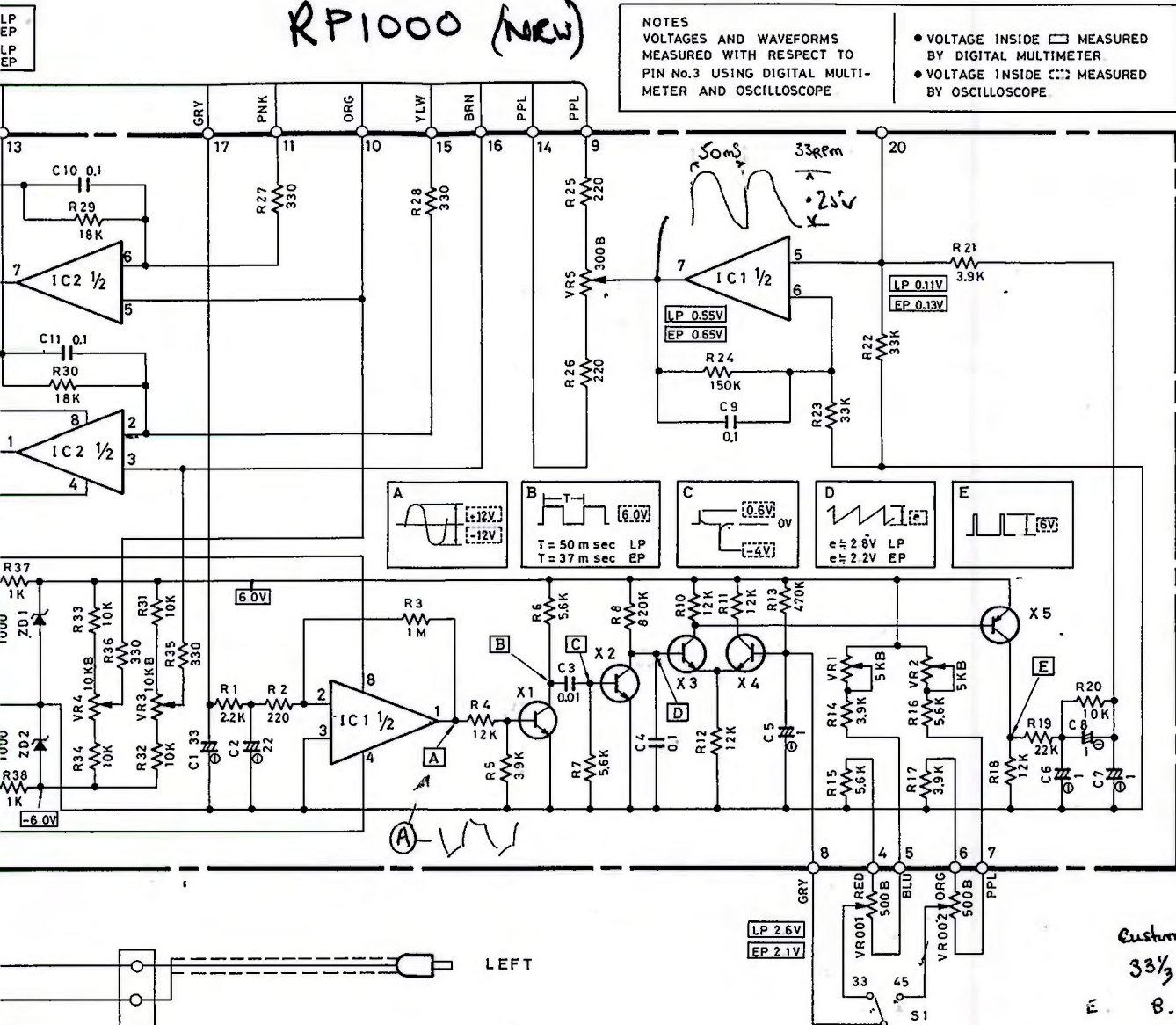

Customer Pot to ~~min~~ min  
 33 1/2 rpm no platter  
 attached

	E	B	C
X 1	0	-0.4 to 0	3.4
X 2	0	0	1.1 approx
X 3	2.0	1.1	6.0
X 4	2.0	2.62	4.1 to 4.2
X 5	6.1	6.0	0.3 approx

## POWER SUPPLY CIRCUIT NETZTEIL CIRCUIT D'ALIMENTATION

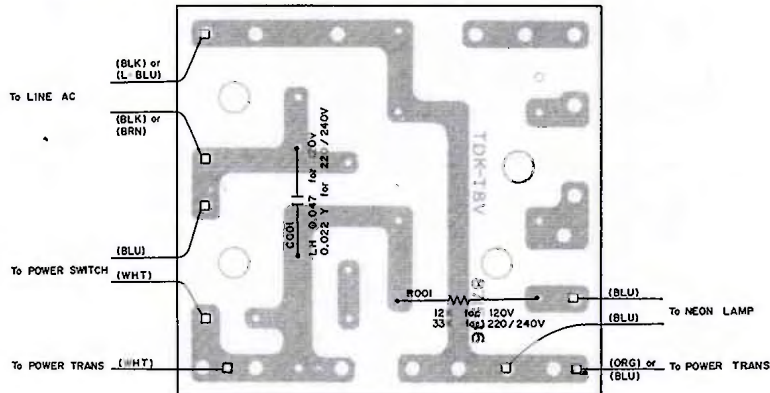
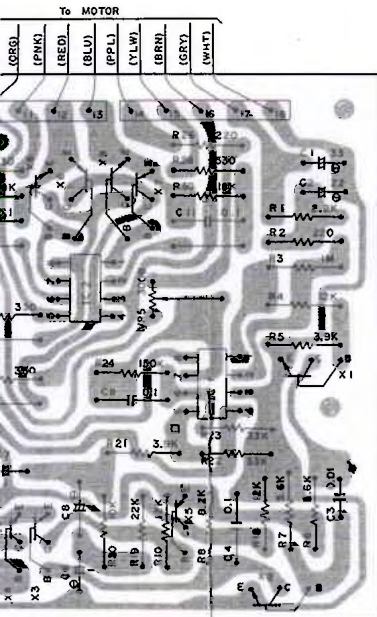

If fault is no go or slow run -  
 ..replace x3, x4 and x5  
 can be checked by heating each then freezing -  
 otherwise they read ok -